



VUE Series

Smart Intercom User manual



Copyright information

Copyright © 2023 My Door View, LLC. All rights reserved.

All intellectual property rights in this publication are owned by My Door View otherwise known as MDV and protected by applicable copyright laws and international treaty provisions. MDV retains all rights not expressly granted. No part of this publication may be reproduced in any form whatsoever or used to make any derivative work without prior written approval by MDV

MDV reserves the right to revise this publication, and/or make improvements or changes in the product(s) and/or the program(s) described in this documentation at any time without prior notice. The information in this document is provided in good faith, but without any representation or warranty whatsoever, whether it is accurate, or complete or otherwise, and on express understanding that MDV shall have no liability whatsoever to other parties in any way arising from or relating to the information or its use.

All other trademarks are the property of their respective owners. Other company and brand products and service names are trademarks or registered trademarks of their respective holders.

This device complies with CE and FCC regulations.



Safety and warning information

Read this user manual

All safety and operating instructions in this user manual should be read before operating the product

Attachments

To avoid danger, please do not use attachments not recommended by the product manufacturer.

Mounting

Flush mount, surface mount, surface mount with rain-hood, gooseneck with rain-hood and Kiosk.

Temperature & Humidity

- Operating temperature 0°F ~ 140°F
- Relative humidity 20%-80%.

The product should be situated away from any heat source such as radiators, heat registers, stoves or other products that produce heat.

Water Intrusion

This unit is IP65 weather rated, it is water resistant - NOT water-proof. Do not install this unit without supplied back-box. Best practice is to seal all back box penetrations with silicone.

Over heating

In direct sun locations, some form of shade is recommended. Over heating from direct sunlight may cause screen de-lamination and therefore not covered by warranty.

Power Supply and Wiring

POE is not recommended for wire runs over 40 linear feet. Must use POE+ type power supply.

Power Supply and Wiring - Continued

12VDC input is also located on back of panel, this is recommended for runs over 40 feet. Minimum 16 AWG wire.

- Minimum 3-amp power supply.
- IF using 12VDC out to power a lock: a minimum 5-amp power supply is required.

Servicing the unit.

Do not field service the unit unless directed by technical support.

Unauthorized service will void your warranty.

Cleaning

Do not use chemicals, use a soft cloth on the screen.

What 's in the box?

- VUE7 Panel
- Mounting Screws
- Backbox
- Speaker Cover

Product overview

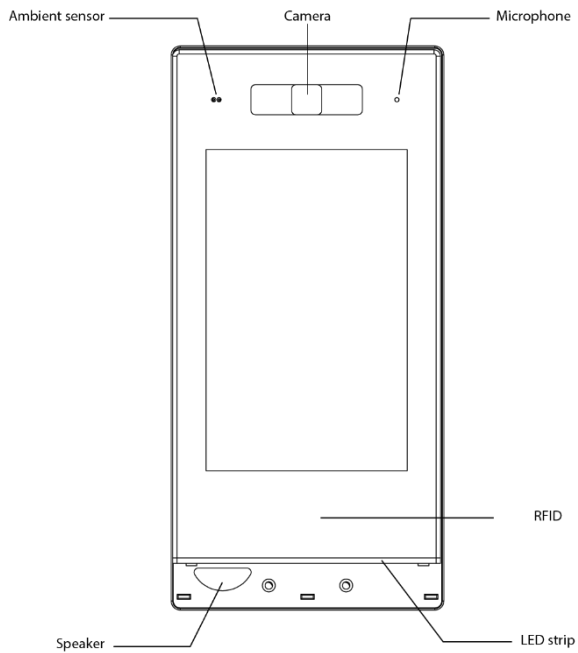

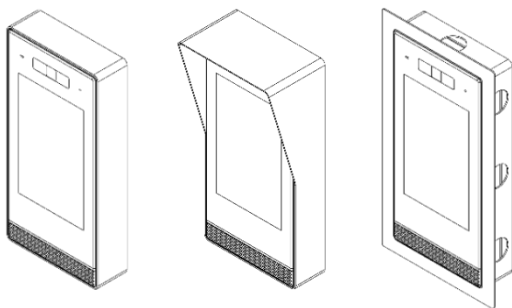

**Surface mount, surface mount with hood and flush mount.
A back box must be used to obtain IP65 rating.**

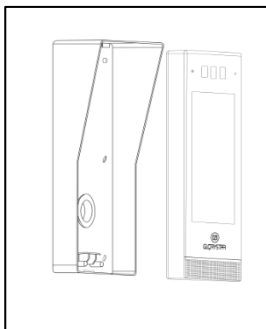
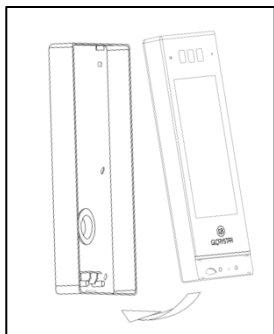

Rear Input/Output

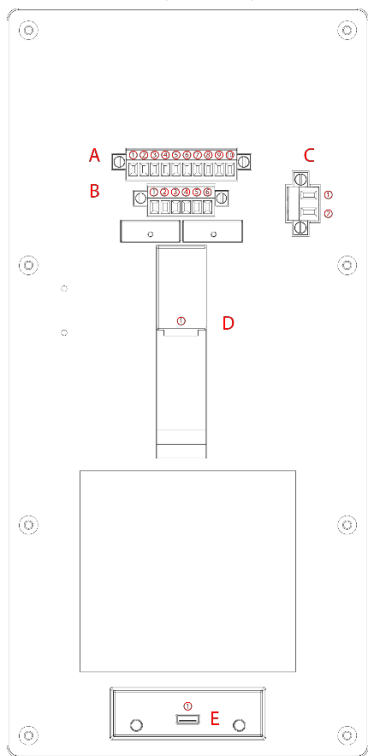

A1	+12V OUT	B1	OUT1
A2	GND	B2	COM1
A3	I/O(INPUT)	B3	NC – not used
A4	I/O(INPUT)	B4	OUT2
A5	+5V OUT	B5	COM2
A6	WIEGAND_D0	B6	NC – not used
A7	WIEGAND_D1	C1	+12V
A8	GND	C2	GND
A9	RS485_A	D	Ethernet with POE
A10	RS485_B	E	MDV USE ONLY

Installation Reference

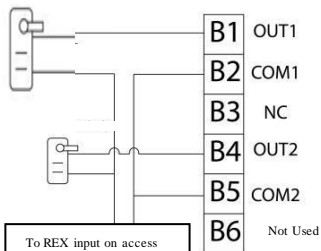

To REX input on access control system or (if stand-alone) lock power supply.

□ 110-220

+12V	A1	Optional 12VDC out 2.5MA
GND	A2	Ground
I/O(INPUT)	A3	FUTURE USE
I/O(INPUT)	A4	FUTURE USE
+5V	A5	Optional 5VDC out 2.5MA
WIEGAND_D0	A6	External Card Reader in
WIEGAND_D1	A7	External Card Reader in
GND	A8	Ground
RS485_A	A9	FUTURE USE
RS485_B	A10	FUTURE USE

Device set-up

B1-B2 = Normally Open/Closed – Programmable (in MDV portal) from 1-99 seconds

B4-B5 = Normally Open/Closed – Programmable (in MDV portal) from 1-99 seconds

D = Ethernet/POE

- No port forward is necessary, plug and play connectivity.
- After initial power up, enter license key.

Note: License keys can only be used once and are associated to the serial number on panel. In the event of panel replacement: MDV Admin will reset license key and all data will automatically reload.

E = Not used

For questions or technical support call 844-596-5801 -or- Email Info@MyDoorView.com